

OWNERS MANUAL

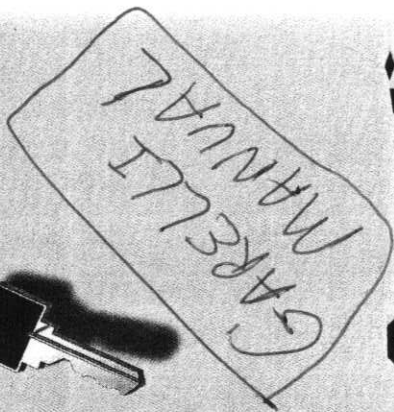
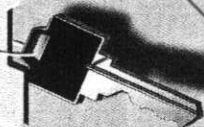
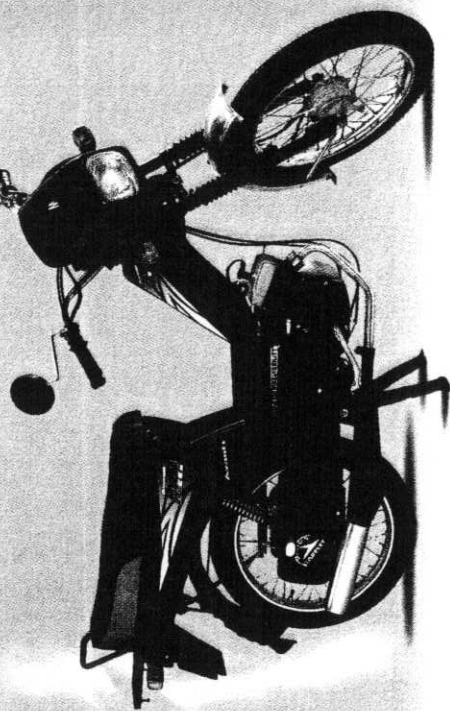

Avanti

Congratulations !!

INTRODUCTION

On being the proud owner of a Avanti moped. Each Avanti moped carries with it, the engineering expertise of Monto Motors Ltd. and technical excellence and reliability of Agrati Garelli spA of Italy. Agrati Garelli vehicles are also known for their fuel efficiency throughout the world.

We at Monto Motors have taken utmost care to give you a trouble free, comfortable and most fuel efficient vehicle.

This vehicle will amaze you with its total trouble free service, incredible fuel efficiency, instant pick up & unbelievable speed in its class.

Please go through this manual completely, specially the chapter on 'running in' of the vehicle. To drive maximum satisfaction from your Avanti vehicle, Drive & Maintain your vehicle strictly in accordance with the instructions given in this manual and your Avanti vehicle shall give you years of trouble free ride.

We thank you for patronising our Moped and remain at your service



**Customer Service Cell
MONTO MOTORS LTD.**

Monto Motors reserves the right to make any modifications / improvement at any time in the specifications without incurring any obligation whatsoever.

CONTENTS

S. No.		Page No.
1.	Know your Vehicle	1-4
2.	Vehicle Identification Marks	5.
3.	Vehicle specifications	6-7
4.	Operating Instructions	8-12
5.	Running in period	13
6.	Tips for better fuel efficiency	14
7.	Daily maintenance schedule	15
8.	Periodic maintenance schedule	16
9.	Lubrication	17
10.	Do it yourself	18-20
11.	Trouble shooting	21-22
12.	Wiring Diagram	23-24
13.	Warranty	25-26
14.	Service Records	
15.	4th Free service cards	
16.	3rd Free service cards	
17.	2nd free service cards	
18.	1st free service cards	
19.	Customer profile card	
20.	PDI Card	

KNOW YOUR VEHICLE

MONT

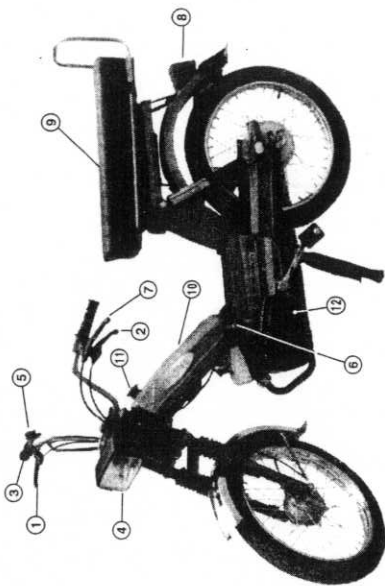

1. Front Brake Lever	7. Rear Brake Lever
2. Starting Lever	8. Tail Light
3. Throttle Grip	9. Saddle
4. Head Light	10. Fuel Tank
5. Light & Horn Switch	11. Fuel Tank Cap
6. Fuel Tap	12. Oil Filler Plug

KNOW YOUR VEHICLE

AUTO POWER

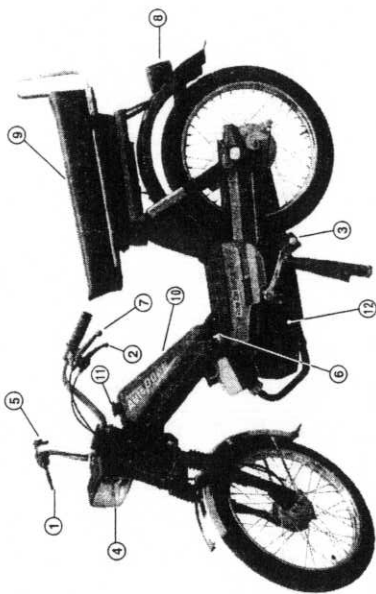

1. Front Brake Lever	7. Rear Brake Lever
2. Starting Lever	8. Tail Light
3. Pedal	9. Saddle
4. Head Light	10. Fuel Tank
5. Light & Horn Switch	11. Fuel Tank Cap
6. Fuel Tap	12. Oil Filler Plug

KNOW YOUR VEHICLE

PORTA 3G

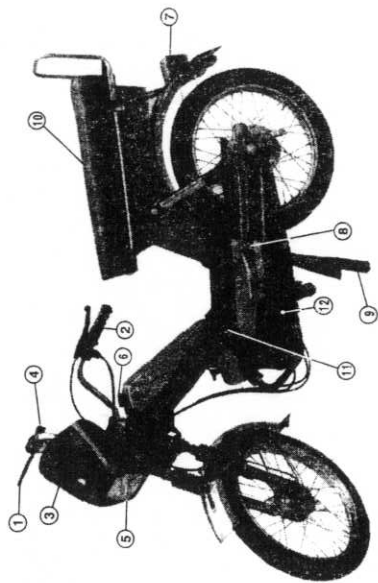

- | | |
|------------------------|---------------------|
| 1. Front Brake Lever | 7. Tail Light |
| 2. Gear Twist Grip | 8. Kick |
| 3. Wind Shield | 9. Stand |
| 4. Light & Horn Switch | 10. Seat |
| 5. Head Light | 11. Fuel Tap |
| 6. Fuel Tank Lid | 12. Oil Filler Plug |

KNOW YOUR VEHICLE

KOBRA 3G

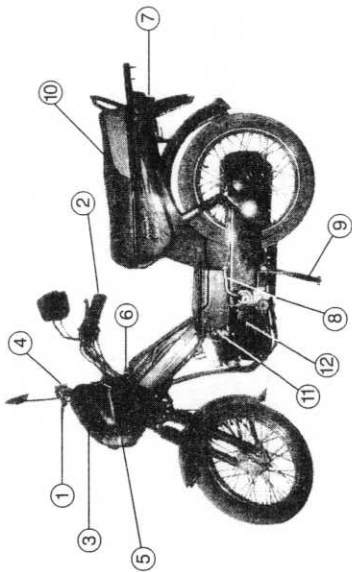

1. Front Brake Lever	7. Tail Light
2. Gear Twist Grip	8. Kick Stand
3. Wind Shield	9. Seat
4. Light & Horn Switch	10. Fuel Tap
5. Head Light	11. Oil Filler Plug
6. Fuel Tank Lid	

VEHICLE IDENTIFICATION MARKS

CHASSIS No.

Chassis No. of each vehicle is stamped on the frame near steering tube as shown in Fig - A



Fig. A Chassis No.

ENGINE No.

Engine No. of each vehicle is stamped on the crank case (R.H.) as shown in the Fig - B

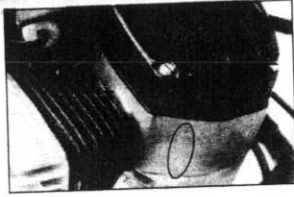

Fig. B. Engine No.

VEHICLE SPECIFICATIONS

	MONT	AUTOPOWER	KOBRA 3G / PORTA 3G
DIMENSIONS			
Overall Length	168 cm.	168 cm.	174 cm.
Overall Width	65 cm.	66 cm.	66 cm.
Overall Height	107 cm.	107 cm.	98 cm.
Wheel Base	112 cm.	112 cm.	112 cm.
WHEEL & BRAKES			
Front Wheel Size	2.25" x 16"	2.25" x 16"	2.25" x 16"*
Rear Wheel Size	2.5" x 16"	2.5" x 16"	2.5" x 16"
Front Tyre Pressure	22 psi (solo) 26 psi (pillion)	22 psi (solo) 26 psi (pillion)	22 psi (solo) 26 psi (pillion)
Rear Tyre Pressure	32 psi (solo) 34 psi (pillion)	32 psi (solo) 34 psi (pillion)	32 psi (solo) 34 psi (pillion)
Brakes Front & Rear	Internally Expanding Shoe type both hand operated	Internally Expanding Shoe type both hand operated	Internally Expanding Shoe type Front hand & Rear foot operated
	Rear Ø 110 & Front Ø 80	Rear Ø 110 & Front Ø 80	Rear Ø 110 & Front Ø 80
GENERAL			
Carrying Capacity	135 Kgs.	135 Kgs.	160 Kgs.
Fuel Tank Capacity	3.2 Litres with reserve	4.5 Litres with reserve	4.5 Litres with reserve
Frame	Tubular Frame	Tubular Frame	Tubular Frame
Suspension Front	Telescopic Fork	Telescopic Fork	Telescopic Fork
Suspension Rear	Swinging Fork with springs and two hydraulic dampers	Swinging Fork with springs and two hydraulic dampers	Swinging Fork with springs and two hydraulic dampers
Nett Weight			

* For Kobra 3G 2.5" x 16"

VEHICLE SPECIFICATIONS

ENGINE	MONT	AUTOPOWER	KOBRA 3G / PORTA 3G
Type	Single cylinder two stroke	Single cylinder two stroke	Single cylinder two stroke
Bore	Air Cooled	Air Cooled	Air Cooled
Stroke	40 mm.	40 mm.	40 mm.
Capacity	39 mm.	39 mm.	39 mm.
Compression ratio	49 cc.	49 cc.	49 cc.
Power output	10.8 : 1	10.8 : 1	10.8 : 1
Carburettor	2.6 BHP @ 5500 RPM	2.6 BHP @ 5500 RPM	2.6 BHP @ 5500 RPM
ELECTRICALS	PACCO. P. 60 MA	PACCO. P. 60 MA	PACCO. P. 60 MA
Magneto	12V 40 W	12V 40 W	12V 50W / 40 W
Spark plug gap / Make	0.4 - 0.6 mm. / MICO W225Z1	0.4 - 0.6 mm. / MICO W225Z1	0.4 - 0.6 mm. / MICO W225Z1
Ignition Timing	12° before TDC at 1500 RPM	12° before TDC at 1500 RPM	12° before TDC at 1500 RPM
Head Lamp	12 V - 25 W / 25 W	12 V - 25 W / 25 W	12 V - 25 W / 25 W
Tail Lamp	12 V - 5 W	12 V - 5 W	12 V - 5 W
Brake Lamp	6 V - 10 W	6 V - 10 W	6 V - 10 W
Horn	12 V AC	12 V AC	12 V AC
Transmission*	Centrifugal Clutch, Oil Bath	Centrifugal Clutch, Oil Bath	Centrifugal Clutch, Oil Bath
	Single Speed	Two Speed Automatic	Three Speed Manual Gear Shift
* Primary drive by gear, final drive by roller chain			

OPERATING INSTRUCTIONS

STEERING LOCK

For safety of your vehicle, a steering lock as shown in Fig 1. is Provided in the vehicle. To Lock the Steering turn handle bar to the extreme left, insert the key, push gently and rotate the key clockwise till the end and pull out the key.

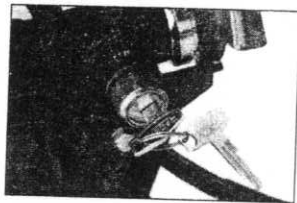

Fig 1.
Steering Lock

OPERATING INSTRUCTIONS

FUEL TAP

Fuel tap has three positions.

1. OFF
2. ON (MAIN)
3. RESERVE

FUEL TANK CAPACITY & RESERVE

MODEL	TANK CAPACITY	QTY OF FUEL IN RESERVE
MONT	3.2 Lit	0.5 Lit
AUTOPOWER	4.5 Lit	0.5 Lit
KOBRA 3G / PORTA 3G	4.5 Lit	0.5 Lit



Fig.2

KEEP THE FUEL TAP IN OFF POSITION WHILE FILLING PETROL

OPERATING INSTRUCTIONS

STARTING THE ENGINE

MONT / AUTOPOWER

Starting of the engine can be done when the vehicle is stationary as also when the vehicle is in motion.

STARTING WHEN THE VEHICLE IS STATIONARY

1. Put the vehicle on stand, thereby raising the rear wheel above the ground.
2. Open the fuel tap (See Fig 2).
3. Rotate (open) the throttle (2) to about 1/3rd.
4. Depress the choke lever (4) Fig 3A.(For cold starting only)
5. Push on the pedal (3) energetically and when the rear wheel begins to rotate, press lever (1) while continuing action on pedal.
6. Release the lever (1)
7. After the engine starts release the choke lever.
8. After the engine starts, depress the rear brake lever & take off the vehicle from the stand and drive on thereafter

STARTING WHEN THE VEHICLE IS IN MOTION

1. Pedal on the vehicle with lever (1) pressed and throttle (2) opened to 1/3rd.
2. Release the lever (1) and the engine will start.

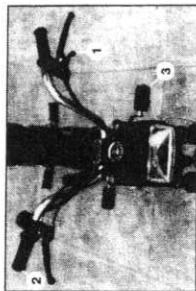

Fig 3.

1. Lever
2. Throttle
3. Pedal

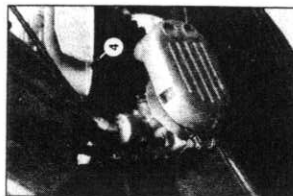

Fig 3 A.

4. Choke Lever

OPERATING INSTRUCTIONS

STARTING THE ENGINE

KOBRA 3G / PORTA 3G

1. Insert the key and rotate clockwise*
2. Open the fuel tap (See Fig 2).
3. Rotate (open) the throttle (1) to about 1/3rd.
4. Ensure that the vehicle is in neutral
5. Start the vehicle by kicking the kick pedal.
6. For changing gears depress the clutch lever (2) and rotate the gear twist grip (3) upwards for 1st gear and downwards for 2nd and 3rd gears.
7. Note that while changing gears the throttle is closed
8. For cold starting the choke lever (Fig 3A) may be used. Ensure to release the choke lever after the engine has started.

*** Ignition lock is available only in KOBRA 3G**

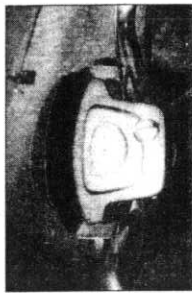

Fig. 4
Ignition Lock for Kobra 3G

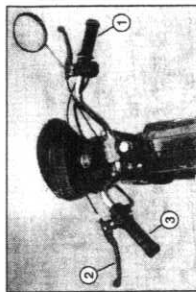

Fig. 4A
1. Throttle
2. Clutch Lever
3. Gear Twist Grip

OPERATING INSTRUCTIONS

TOOL KIT

A tool kit containing following tools is provided with every vehicle, to enable the rider to do emergency repairs / normal maintenance. The tool kit is placed in the tool box provided beneath the seat.

TOOLS

1. Spark Plug Spanner
2. Screw Driver
3. 17 - 19 spanner
4. 8 - 10 spanner
5. Tommy bar

- Push the lever (A) to the right
- Lift the seat up as shown in the Fig.
- KOBRA 3G - A lock is provided for tool kit. To open insert the key in the lock , press and rotate clockwise and lift the seat.



Fig. 5.
(1) Lever (A)

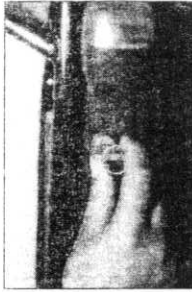

Fig. 6
Tool Kit Lock for Kobra 3G

"RUNNING IN" PERIOD

The most important period of a vehicle is its first 1000 Kms. run, also known as running in period. In a new engine, all the moving parts need to set to their working tolerances and if they are strained excessively in the initial run, the engine life is reduced substantially. Therefore we strongly recommend you to drive your vehicle carefully during this period and follow the guide lines given hereunder.

DO

- Mix only 2-T oil with petrol and in the recommended quantity (40 ml. per litre of petrol).
- Always keep correct tyre pressure.
- Always keep correct chain tension.
- Allow the engine to cool down after every 30 Kms. on continuous drive.

DO NOT

- DO NOT drive the vehicle beyond 40 Kmph speed.
- DO NOT Overload the vehicle.
- DO NOT give sudden acceleration.
- DO NOT apply sudden brakes unless absolutely necessary.
- DO NOT park the vehicle under hot sun.
- DO NOT drive with under / over inflated tyres.
- DO NOT give full throttle when the vehicle is stationary.

TIPS FOR BETTER FUEL EFFICIENCY

DO

- Drive below 40 Kms/hr speed.
- Anticipate the stoppage to avoid sudden braking
- Always use recommended 2T oil.
- Check tyre pressure regularly and maintain as specified.
- Switch off the engine if anticipated stoppage is more than 1 minute.
- Maintain the chain tension as specified.
- Get your vehicle serviced regularly only at Authorised Service Stations.

DO NOT

- DO NOT drive beyond the specified speed.
- DO NOT accelerate the engine when the vehicle is stationary.
- DO NOT carry more load than specified.
- DO NOT drive your vehicle with half brake / clutch.

DAILY MAINTENANCE SCHEDULE

Before riding your vehicle please check your vehicle for the following. Never neglect the importance of this inspection as they are concerned with your safety as well as that of your vehicle.

DESCRIPTION CHECK

Tyre	: For proper inflation. : For nails / any other sharp objects. : For cracks & cuts
Brakes	: For correct free play of brake levers & effectiveness.
Electricals	: For proper functioning of all lights & Horn.
FUEL	: For sufficient quantity.
Chain	: For proper tension of the chain.
Throttle	: For free play in throttle cable & positive return to the closed position.
Steering	: For smoothness and free movement.

PERIODIC MAINTENANCE SCHEDULE

COMPONENT	750 - 800 Kms.	EVERY 2000 Kms.	EVERY 6000 Kms.	EVERY 6000 - 9000 Kms.
CLUTCH	I	I		
SPARK PLUG	I	I		
CARBURETTOR	C	C&I	C	R
NUTS & BOLTS	I	I		C&I
GEAR BOX OIL	D	D	D	I
CONTROL CABLES	I	I		D
FUNCTIONING OF ELECTRICALS	I	I		I
DECARBONISE CYLINDER & HEAD	-	-	C	I
STEERING COLUMN	I	I	L	-
AIR FILTER	C	C	C	L
WHEEL BEARING	-	-	L	C
CHAIN	I&L	I&L	I&L	I&L

C - CLEAN

D - DRAIN & REFILL WITH FRESH OIL

R - REPLACE

I - INSPECT, CHECK & ADJUST

L - LUBRICATE

FILL ONLY "SERVO 20 W 40" OIL IN GEAR BOX

LUBRICATION

A. MIXING OIL WITH PETROL

1. Use 2-T oil 4% (40 ml of 2-T oil per litre of petrol) for 1st 1000 Kms.
2. Use 2-T oil 3% (30 ml of 2-T oil per litre of petrol) after 1st 1000 Kms.

ALWAYS USE SEALED CONTAINERS OF 2-T OIL

B. GEAR BOX OIL

Grade
Qty

Servo 20 W 40

For Mont / Autopower 350 ml.
For Kobra 3G / Porta 3G 450 ml.

RECOMMENDED TYRE PRESSURE

Front tyre pressure	SOLO	PILLION
Rear tyre pressure	22 psi	26 psi
	32 psi	34 psi

DO IT YOURSELF

SPARK PLUG

- Disconnect the plug adapter. (1)
- Remove the spark plug using the plug spanner provided in the Tool Kit.
- Clean the plug electrodes with wire brush.
- Remove all foreign material by blowing air.
- Adjust the gap as specified in the Fig 6.
- Assemble the plug and connect the adapter.

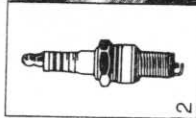

Fig. 6

1. Adapter.
2. Spark Plug gap (0.4 - 0.6 mm.)

RECOMMENDED SPARK PLUG IS "MICO W 225 Z1"

AIR FILTER CLEANING

- Slacken the clamping screw (2)
- Pull out Air filter assembly from carburettor.
- Take out Air filter from intake cover.
- Wash the air filter with diesel or detergent solvent.
- Blow compressed air and reassemble.

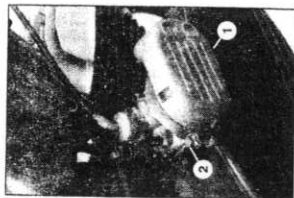

Fig. 7

1. Air filter assy.
2. Clamping Screw.

CLOGGED AIR FILTER OR SPARK PLUG WILL REDUCE THE MILEAGE

DO IT YOURSELF

BRAKES ADJUSTMENT

Front Brake

- Check the free play of the front brake lever.
- Loosen the adjuster lock nut by using 8 - 10 double ended spanner.
- Position the adjuster while pulling the brake wire with a plier and tighten the lock nut.
- Ensure the required play at the brake lever.

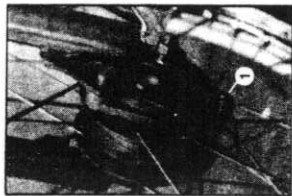

Fig.8
1. Adjuster lock nut.

Rear Brake

- Measure the free play of the rear brake lever. (Foot brake lever is provided in Kobra 3G / Porta 3G)
- Free play should be 10 - 15 mm.
- Adjust the brakes by rotating adjusting screw (2) anti clockwise or clockwise as required.



Fig.9
2. Adjusting Screw

ALWAYS USE BOTH THE BRAKES FOR EFFICIENT BRAKING

DO IT YOURSELF

CHAIN TENSION

- Excessive slack of chain will cause poor performance
- Loosen the rear wheel axle nut by using 19 mm. ring spanner.
- Adjust the chain by rotating the chain adjuster.
- Tighten the rear wheel axle nut.
- Adjust the brakes accordingly.

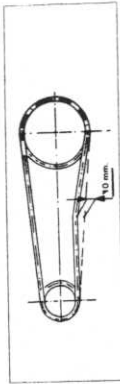

Fig. 9

1. Rear wheel axle nut
2. Chain adjuster

ENSURE TO ROTATE THE CHAIN ADJUSTERS BY EQUAL DISTANCE ON BOTH SIDES OTHERWISE IT WILL DISTURB THE WHEEL ALIGNMENT

TROUBLE SHOOTING

DEFECTS

PROBABLE CAUSES

REMEDIES

STARTING TROUBLE

FUEL SYSTEM

- Fuel tank empty.
- Carburettor jet clogged.
- Carburettor float stuck.
- Air filter choked or dirty.

- Refill.
- Remove and clean the jet.
- Clean carburettor & set.
- Clean with solvent.

IGNITION SYSTEM

- Spark plug dirty / short or wrong type.

- Clean & adjust gap.
- Change to recommended MICO W 225 Z1 or equivalent.

LOW FUEL ECONOMY

- Less inflated tyres.
- Excessive slack in chain.
- Faulty carburettor system
- Faulty plug / improper gap.
- Improper tuning
- Faulty brake free play
- Faulty clutch adjustment

- inflate to proper pressure
- Correct chain tension.
- Service the carburettor.
- Replace / reset.
- Tune properly.
- Adjust properly
- Adjust properly

TROUBLE SHOOTING

DEFECTS ENGINE LACKS POWER

PROBABLE CAUSES	REMEDIES
Exhaust port and silencer clogged.	Contact nearest AVANTI dealer.
Insufficient fuel supply.	Clean the fuel system.
Improper spark plug gap	Adjust to 0.4 - 0.6 mm.
Defective spark plug	Replace
Compression leakage	Contact nearest AVANTI dealer.
Low compression pressure	Contact nearest AVANTI dealer.
Carbon deposits in Cylinder / Head	Contact nearest AVANTI dealer.

ELECTRIC WIRING DIAGRAM

MONT & AUTOPOWER, J&J

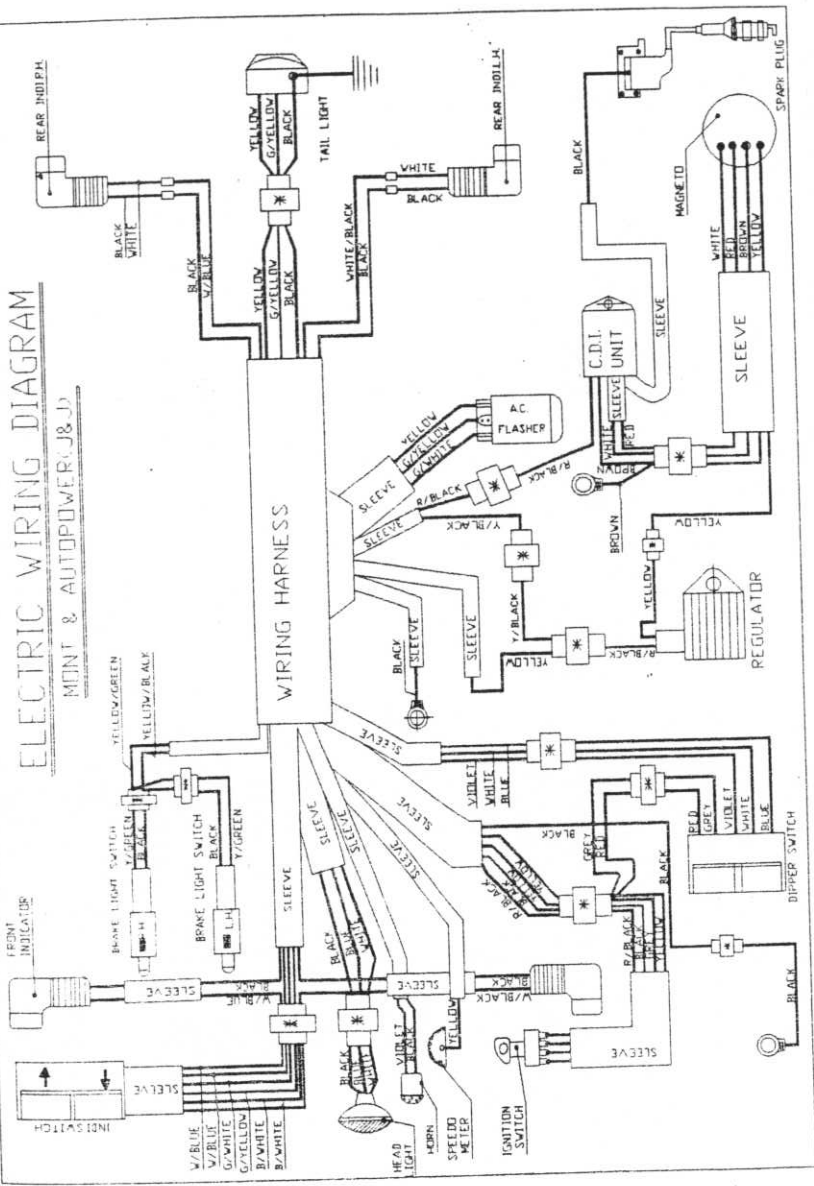

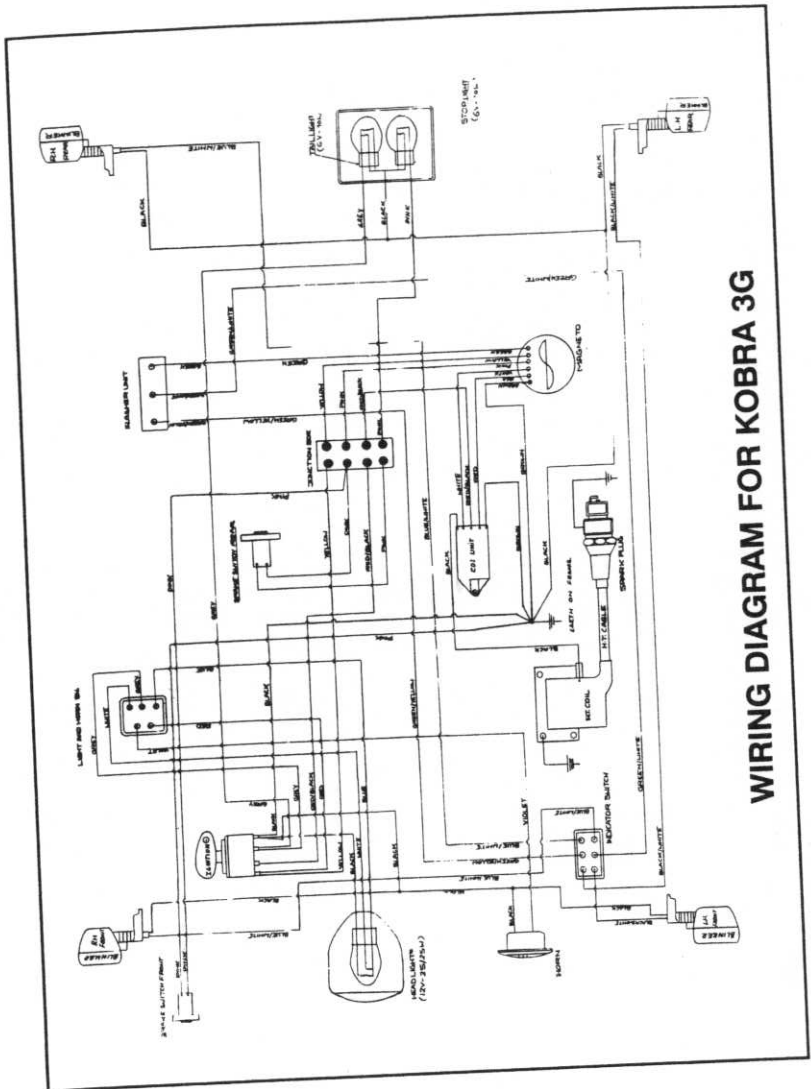

WIRING DIAGRAM FOR KOBRA 3G

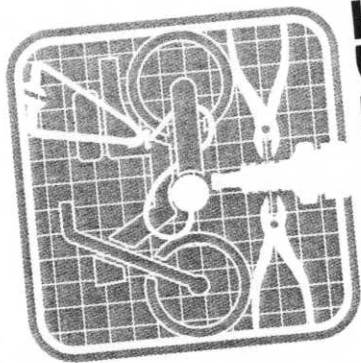

SERVICE

USE GENUINE AVANTI SPARES
FOR BETTER PERFORMANCE